



Application Note

AH114 70 MHz Reference Design

Summary:

The AH114 is a high linearity, ¼-W amplifier targeted at mobile infrastructure. As specified on the datasheet, the InGaP HBT amplifier typically achieves 14.5 dB gain, 41 dBm OIP3, and 23 dBm P1dB with an input/output return loss of better than 10 dB at 1.9 GHz. **This application note details the operation and schematic of the AH114 targeted at the IF frequency of 70 MHz.** The tuned AH114 70 MHz application circuit produced 23 dB gain, 24 dBm P1dB, and 44.5 dBm OIP3 with an input / output return loss of better than 14 dB. The amplifier contains an internal active bias and requires only a single +5 V supply that can be sourced directly from a voltage regulator. This circuit is ideal for use as a driver amplifier for IF applications requiring high linearity and/or output power.

Measured RF Performance

Frequency	70 MHz
S21 – Gain	23.4 dB
S11 – Input Return Loss	-15 dB
S22 – Output Return Loss	-14 dB
Output IP3 (+10 dBm / tone, 1 MHz spacing)	+44.5 dBm
Output P1dB	+23.8 dBm
Noise Figure	6.5 dB
Supply Voltage	+5 V
Supply Current	150 mA

Measured parameters were taken at 25 °C.

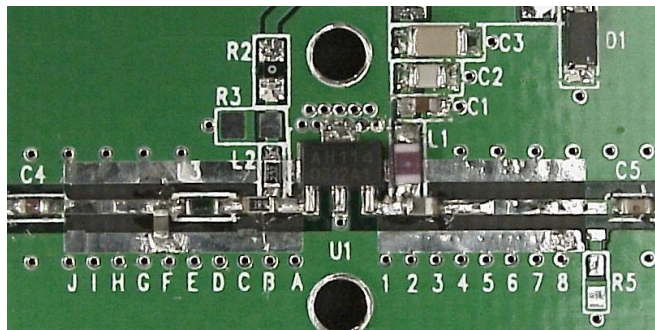
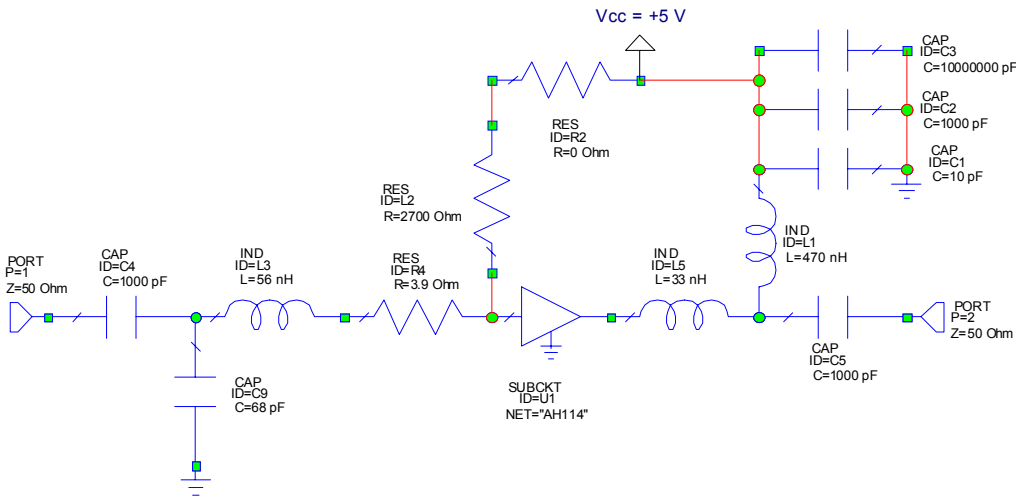
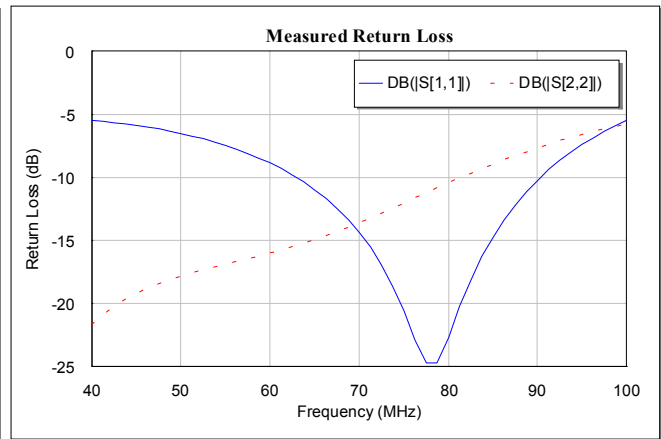
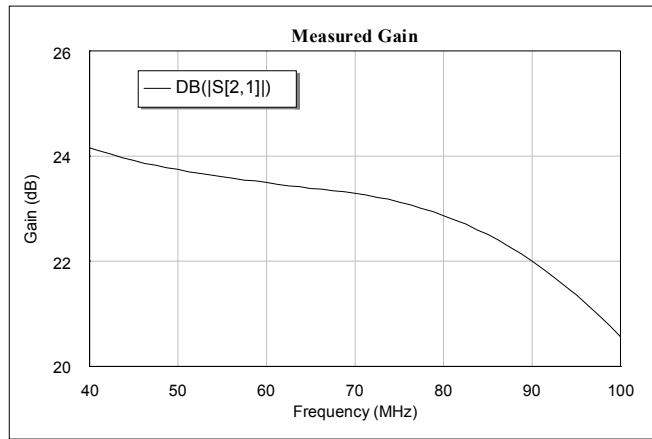

Circuit Board Material: .014" FR-4, 4 layers, .062" total thickness

Bill of Materials

Ref. Desig.	Size	Component
C1	0603	10 pF chip capacitor
C2, C4, C7	0603	1000 pF chip capacitor
C3	1206	10 µF chip capacitor
C9	0603	68 pF chip capacitor
L1	0805	470 nH wirewound inductor
L2	0603	2.7 kΩ chip resistor
L3	0603	56 nH chip inductor
L5	0603	33 nH chip inductor
R2	0603	0 Ω chip resistor
R4	0603	3.9 Ω chip resistor
U1		WJ AH114 Amplifier

Specifications and information are subject to change without notice